



REMU

Big Float

Amphibious Excavator



Big Float leads the Way



Index

Applications	3
Dimensions	4-5
Extra pontoons and anchoring legs	6
Transportation	7
Contact information	8

Challenging projects related to infrastructure, environment, water ways and waste ponds has been problem for decades. The Big Float amphibious excavator is innovative solution for earth moving projects under challenging conditions. It is designed to operate in marshland and shallow-water areas, where working with traditional excavator is dangerous or even impossible.

The first Big Float was manufactured in 1994. Since then, the idea of a floating excavator that can be narrowed has been designed and improved so that today we can offer the most sophisticated and mobile floating excavator in the market.



Big Float –The Only Way to Work in Demanding Conditions



Big Float doesn't need any crane assistance since it can be driven right into the water with its tracks. It is ready to work instantly in various applications.

Removing vegetations

With Big Float it is safe to drive into soft shoreline to clean off the vegetation.

Cleaning industrial ponds

Big Float is able to move almost anywhere including challenging waste ponds containing zero fiber waste.

Dredging and removing sediment

Dredging can be done with a standard cleaning bucket or with a special suction dredging bucket. Bucket designed for suction dredging blends the right amount of water to silt and prevents stone from

getting into the pipes.

Infrastructure

Environmental work, preparation of water ways, pile driving, cleaning the canals, laying cables and pipes can all be done in areas where it has been impossible or expensive before.





Big but not Clumsy!

Big Float amphibious excavators are manufactured in three sizes. Starting point of every Big Float is the superstructure of standard excavator that can be almost any of the major excavator brands. To manufacture Big Float the standard excavator is modified by replacing normal boom with the long reach boom and removing counterweight. The old undercarriage is replaced with pontoon structure.

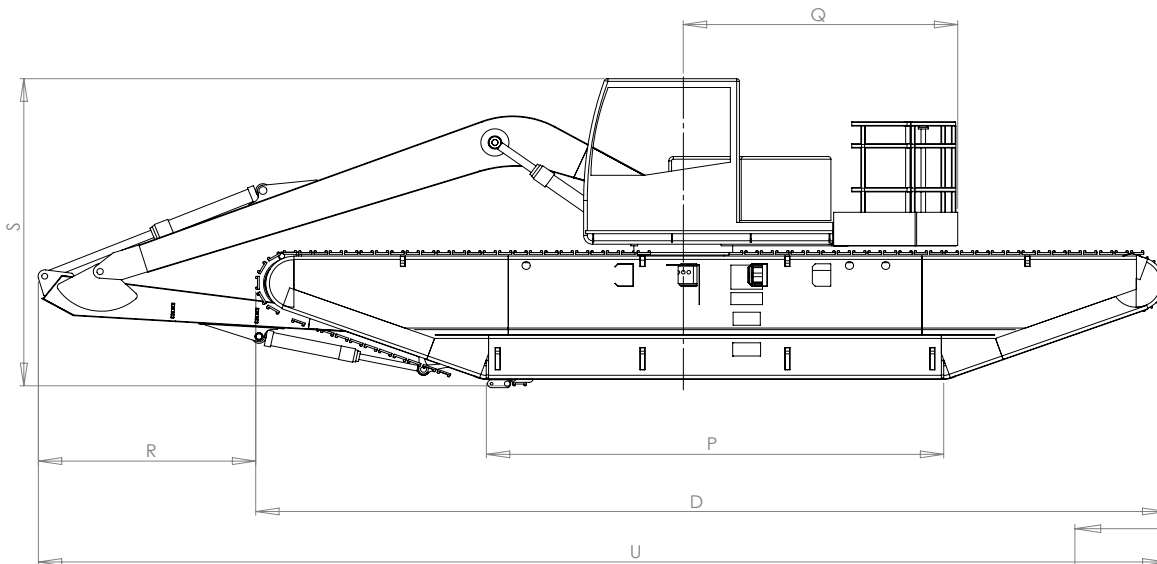

Big Float models technical dimensioning

	10.22	12.24	16.36	
A min.	3	3	3,5	m
A max.	4,8	4,8	5,5	m
A driving	3,6	3,6	4,1	m
B	1,4	1,4	1,6	m
C	5	6	6,3	m
D	10,2	11,2	11,2	m
I	1,01	1,11	1,23	m
J	0,4	0,4	0,4	m
K	1,2	1,2	1,2	m
L	1,3	1,3	1,5	m
M driving	2,3	2,3	2,6	m
N	1,54	1,54	1,74	m
O	2,97	2,97	3,48	m
P	5	6	6,3	m
Q	3,03	3,19	3,64	m
R	2,4	2,5	3,2	m
S	3,51	3,56	3,785	m
T	1,6	1,66	1,89	m

All values imetric meters

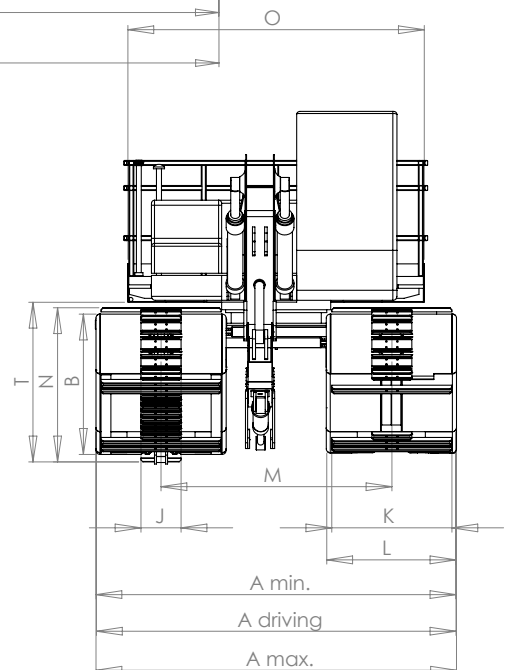

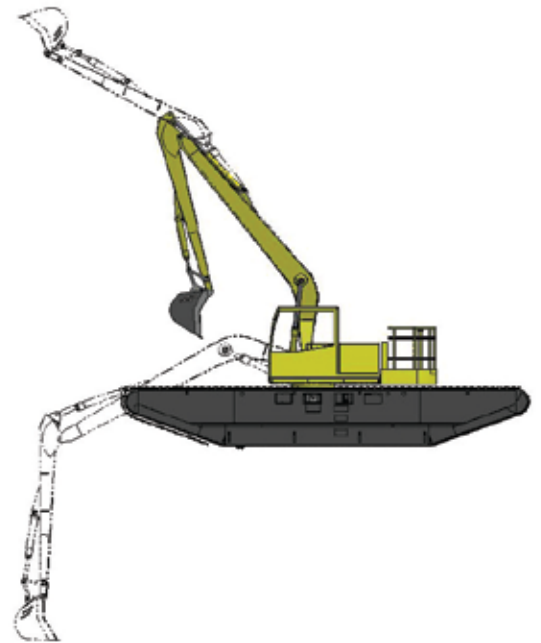
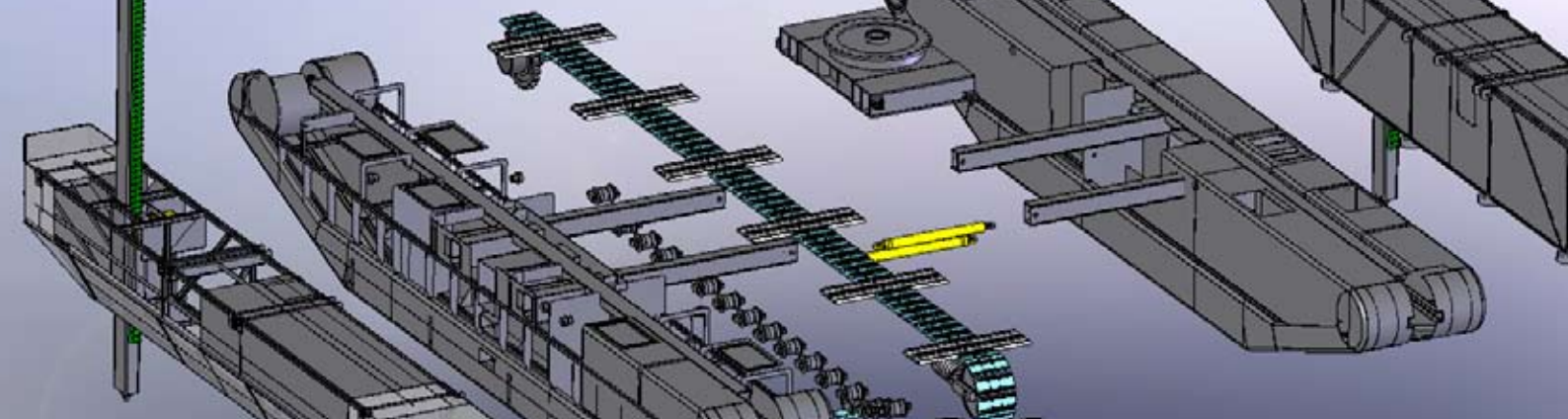

Big Float	10.22	12.24	16.36
Maximum working depth without outriggers	1.3 m	1.4 m	1.5 m
Outreach (in front)	10.0 m	12.0 m	15.0 m
Digging depth	4.5 m	7.5 m	9.0 m
Ground pressure on land	140 g/cm²	160 g/cm²	160 g/cm²
Lower Chassis assembly	15350	15900	18150 kg
Operationg (estimated with average base machine)	22000	25000	35000 kg

Pontoon structure

Tracks of the Big Float are similar to a standard excavator. The pontoon structure is divided into 8 baffle sections to ensure safe floating. Part of the quality control of the manufacturing process is pressure checking the pontoons.

The Pontoon structure is connected to the excavators own rotation unit. The width can be hydraulically adjusted by the operator. Pontoon structures can be equipped with four hydraulic functions like pontoon adjustments, anchoring legs, propellers etc.



Working in Open Water



With extra pontoons and outriggers Big Float can steadily work in open water reaching down to 9 meters.

Extra pontoons and Anchoring legs

With extra pontoons and anchoring legs, Big Float can be secured, to be stable while operating machine in open water. With these additional devices Big Float can securely work. Supporting legs are manufactured in two lengths: 6 or 1,5 meters. The shorter legs can be used if there is no intention to operate in deeper water.

Propellers

Since Big Float is totally floating, it is easy to move Big Float via water ways by using propellers that can be attached to extra pontoons. Propellers get the power from the track systems which allows the same control in the water as it is on land.



REMU



One Standard Transportation!



One of Big Float's innovative features is the hydraulic pontoon structure that can be narrowed for transportation. Total width of Big Float in transportation position is only 3 meters where upon there is no need for special transportation arrangements such as, cranes and multiple transports.

Loading and unloading

Big Float can be driven onto lowboy with its own tracks and there is no need for crane assistance. Loading or unloading Big Float takes only half an hour and it is instantly ready for operation.

Driving

Surface pressure that Big Float directs towards ground is only 160g/cm².





**The Only Way to Work
in Demanding Conditions!**

Main office:
REMU Finland
+358 (0)207 431 160
info@remu.fi

North/South American operations:
REMU USA Inc.
+1 888 600 0018
usa@remu.fi

REMU
www.remu.fi

Your Dealer: